

DESIGN COMPETITION RULES

Judging Criteria

NOTE: Anyone judging Horticultural or Design classes at this show may NOT enter any Horticultural or Design class on either day.

1. All Design and Horticultural exhibits will be judged by a designated team of judges selected by the Toronto Flower Show Convenors.
2. Anyone judging this year's show will not be permitted on the show floor during entry times for exhibits.
3. No one other than those authorized by the Show Committee will be permitted into the area of the Toronto Flower Show where judging is in progress and no one may discuss the exhibits with the judges prior to judging.
4. Designs must not be altered in any manner after being passed by the passing committee and judged. Deteriorating plant material however, must be replaced in order to keep the exhibit in show condition. A design committee member may assist you in keeping your design in show condition **provided you have replacement material available at the show.**
5. The decision of the Judges is final.

The following rules apply to all Design Competitions. Note that only non-professionals may compete.

1. General Regulations (pages 6- 8) Judging Criteria (above) and the *Ontario Judging and Exhibiting Standards for Horticulture and Floral Design* (2003 edition) apply.
In addition, International Flower Show Rules, World Association of Floral Artists (WAFA) will apply:
 - a) An exhibit is made of plant material, with or without accessories, within a space specified in the Show Schedule.
 - b) Plant material must predominate over all other components of the exhibit.
 - c) The use of artificial plant material is forbidden unless stated in the regulations.
 - d) Fresh plant material must be in water or in water-retaining material unless such material remains turgid throughout the event.
 - e) Painted and/or artificially coloured plant material may be used unless otherwise stated in the regulations.

For this show only, portions of any Design entry requiring work not able to be completed in the time allotted may be done in advance.

In the event of any conflict, the above rules will prevail.

2. Exhibitors are requested to notify convenors as soon as possible, which dates and classes they wish to enter. Do not wait to be called. Space will be reserved for each exhibit when notice is received and confirmed by email, telephone or letter. **Exhibitors unable to fulfill their responsibility must find their own substitute.**
3. Exhibitors may submit only 1 exhibit in each class.
4. All classes are limited to 5 exhibits each entry day except where noted in the Schedule.
5. First day exhibits will be received between 8:00 p.m. and 11:00 p.m. on Thursday March 7, and between 6:00 a.m. and 9 a.m. on Friday, March 8, 2019. First day exhibits must be removed at 5:30 p.m. on Tuesday, March 12, 2019.
6. Second day exhibits will be received between 6:00 p.m. and 11:00 p.m. on Tuesday, March 12 and between 6:00 a.m. and 9:00 a.m. on Wednesday, March 13, 2019.
7. All designs must be in place and ready for the Passing Committee at the following times:
Friday, March 8, 2019 by 9:00 a.m. for judging at 9:30 a.m. They must remain in place until removal on Tuesday, March 12 at 5:30 p.m.
Wednesday, March 13 by 9:00 a.m. for judging at 9:30 a.m. There will be a warning bell 15 minutes prior to the time of clearing the judging area on both entry days.
8. If a design has a mechanical failure after the entry time is closed, it may not be repaired until judging is completed. After judging it must be repaired to its original status for the duration of the show.
9. No exhibit may be altered in any manner after it has been judged, except to restore it to its original condition according to Judging Criteria Rule #4.
10. Maintenance may be done at any time during the show, including public open hours. Please ensure that you are wearing appropriate ID.
11. The Toronto Flower Show Chair and/or the Floral Design Chair may remove an exhibit if deemed necessary.
12. All exhibits must be removed promptly on Sunday, March 17 at **5:00 p.m.**

13. **All designs must be made and staged by the exhibitors themselves. Any competitor receiving help with put-in other than help that is physically necessary will be disqualified.**
14. All exhibitors are asked to leave their completed entry sheet with their design at the time of entry. It should include: name, class, date, a list of plant material in the design, including both common and botanical names and explanation of containers of interest. See *Snippy Tips #1*. **Novice designation must be included on the entry sheet.** The list of material in the design should be duplicated in block capitals or typed on a 4" x 6" card to be available for the judges.
15. Check with your class convenor to see that your design meets all requirements set out in the schedule. **A design which does not comply will not be judged. You may not leave the design area until your design is accepted by the Passing Committee.** This will be at the sole discretion of the Design Committee Chair. This will be indicated by the letter **P** marked on your entry card.
16. While every effort has been made to ensure accuracy, note that measurements may vary slightly.

Regarding liability - see General Regulations page 7.

Points Awarded

First	6 points
Second	4 points
Third	2 points
Honourable Mention	1 point

Scale of Judging Points (except where otherwise stated)

Design: Organization of the elements and principles.	35 points
Conformance: Compliance with scheduled requirements, theme.	25 points
Creativity: Originality of concept in choice of components, and/or organization of design elements according to the principles of design.	20 points
Distinction and Condition: Marked superiority and physical state of plant material at time of judging	20 points

Scale of Points for Tables: see *Ontario Judging Standards* (2003 edition)

Scale of Points for Miniatures: see *Ontario Judging Standards* (2003 edition)

Deductions will be proportionate to the degree of non-compliance.

NOTE: throughout the schedule, * denotes Benjamin Moore paint

DESIGN COMPETITION SCHEDULE DAY 1

Friday, March 8, 2019

Set up: Day 1 exhibits will be received between 8:00 p.m. and 11:00 p.m. on Thursday, March 7, and between 6:00 a.m. and 9:00 a.m. on Friday, March 8, 2019.

Removal: First day exhibits must be removed at 5:30 p.m. on Tuesday, March 12, 2019.

Class 101 GATHERING of the CLAN

NOVICE CLASS- Open to members of The Garden Club of Toronto who have not previously won a red ribbon in any major Garden Club of Toronto show or Toronto Flower Show (at Canada Blooms) (excluding monthly Neil Cup and Margaret Dove competitions).

A Mass design

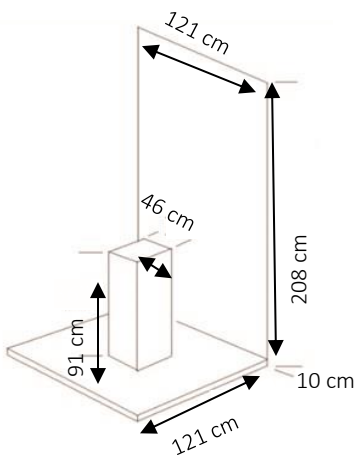

Staged on a pedestal 46 cm wide X 46 cm deep X 91 cm high (18" x 18" x 36") on a base 121 cm wide x 121 cm deep x 10 cm high (48" x 48" x 4") against a background panel 121 cm x 208 cm (48" wide x 82" high)

Area Allotted: 121 cm wide x 121 cm deep x 208 cm high (48" x 48" x 80")

Limited to 5 entries

Pedestal, Base and background colour: Blue Lake 2053-40

Convenors:

Dianne Gillin: 416-929-7176 dianne.sloangillin@gmail.com

Marsha Pine: 416-461-4466 mpine@rogers.com

Class 102 SUNDAY BEST

A Hat made from plant material. Plant material may be painted. Head will be supplied to exhibitor in advance. Designer may paint head in colour of choice.

Staged on a 107 cm high pedestal (42") with a 46 cm diameter top (18")

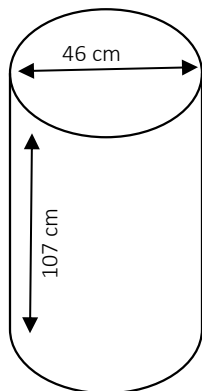

Area Allotted: 76 cm wide x 76 cm deep (30" x 30")

Limited to 5 entries. This exhibit will remain in the show for 10 days.

Exhibit will be judged from the front but viewed from all sides.

Pedestal: 2000-10 Red
Top: Black

Convenors:

Judy Lewis 416-964-7907 judlewis@yahoo.ca

Rosemary Passafiume-McLean 416-284-6969

rosemary.passafiume.mclean@gmail.com

Class 103 DRESSING UP

Jewellery made from plant and/or plant-based material. Mounted on a board 38 cm wide x 38 cm deep (15" x 15"). Board will be supplied to exhibitor. Entry may extend beyond the board at Exhibitor's discretion.

Limited to 6 entries. Exhibit will remain in the show for 10 days.

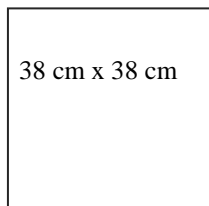

Staged on an easel sitting on a 25 cm wide x 25 cm deep x 5 cm high (10" x 10" x 2") acrylic riser in a niche 60 cm wide x 76 cm deep x 74 cm high (24" x 30" x 29 3/4").

Niche: Black.

Convenors:

Marsha Pine 416-461-4466 mpine@rogers.com

Lil Taggart 289-891-9668 liltovey@hotmail.com

Class 104 FAMILY TREE

A Mobile Design incorporating a branch(s) to be equipped to hang and must not exceed in 4.5 kg in weight (10 lbs). A design suspended from one point, composed of linked shapes, each of which is capable of movement. Mobiles are based on the art form developed by Alexander Calder. They are abstract compositions of balanced moving parts suspended from above. Interest must be equal throughout all parts of a mobile. It must be able to move freely in gentle air currents.

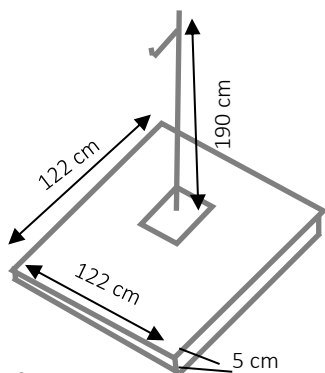

Staged to be hung from a black free-standing wrought iron stand on a base 122 cm wide x 122 cm deep x 5 cm high (48" x 48" x 2"). Hook for hanging will be approximately 190 cm (75") above the base.

Limited to 5 entries.

Area Allotted: 122 cm wide x 122 deep cm (48" x 48")

Base: Brilliant Blue 2065-30

Convenors

Trudy Grantham 416-691-5333 tgrantham@sympatico.ca

Deborah Maw 416-966-2856 openarms@pathcom.com

Class 105 HEIRLOOM

A Tapestry Design. A solid mass design with a geometric closed silhouette(s). Imaginative design technique(s) and applications must be used, e.g. pillowing, pave, colour blocking, bunching, weaving, etc. Inner space is achieved by overlapping planes and/or other components, by groupings of like colours, textures, and forms, and/or by juxtaposing contrasting groupings or other components.

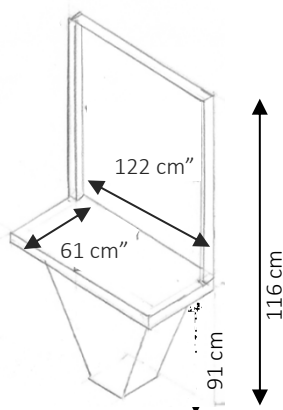

Staged on a shelf 122 cm wide x 61 cm deep (48" x 24") 91 cm (36") above the floor.

Area Allotted: 112 cm wide x 61 cm deep x 116 cm high (44" x 24" x 46")

Limited to 5 entries.

Background and shelf: Brilliant Blue 2065-30.
Frame colour: Simply White OC117

Convenors

Deborah Landers 416-485-3557 landers@rogers.com

Celia Roberts 905-335-8555 celiaroberts62@bell.net

Class 106 A PICTURE IS WORTH A THOUSAND WORDS

A Design in a 56 cm wide x 76 cm high (22" wide x 30") free standing frame. Frame will be supplied. Frame may be painted by exhibitor. Design may extend beyond the frame.

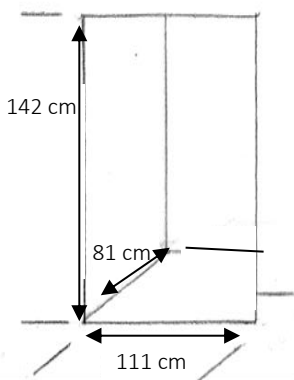

Staged in a niche 111 cm wide x 81 cm deep x 142 cm high (44" x 32" x 49")

Area Allotted: 111 cm wide x 81 cm deep x 142 cm high (44" x 32" x 49")

Limited to 5 entries

Niche colour: Red 2000-10

Set colour: Blue Lake 2053-40

Convenors:

Ellen Clark 416-486-9352 ellen.clark@sympatico.ca

Heather Gray 416-445-2910 hgrayis@rogers.com

Class 107 FAMILY GAME NIGHT

A Pavé Design. Pavé is a design technique of placing groups of plant material that have been cut short, close together to form undulating mounds of colours, textures, shapes and sizes. Any plant material, e.g., flowers, foliage, cut stems, fruits, vegetables, moss, etc. can be used. Staged on a cube 60 cm wide x 60 cm deep x 60 cm high (24" x 24" x 24").

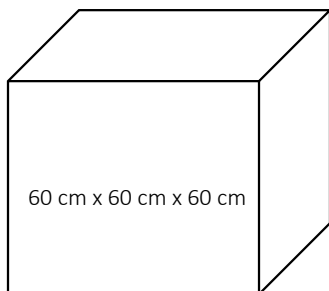

Area Allotted: 76 cm wide x 76 cm deep (30" x 30")

Limited to 5 entries

Cube colour: Brilliant Blue 2065-30

Convenors:

Tara Bramall 416-489-5385 tara8@rogers.com

Janet Marsh 416-483-7417 janetem12@icloud.com

Class 108 FAMILY CIRCLE

A miniature design using predominately fresh plant material.

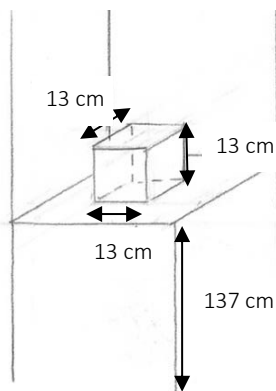

Staged in a clear acrylic cube 13 cm wide x 13 cm deep x 13 cm high (5.25" x 5.25" x 5.25") set on a pedestal 137 cm high (54") against a background. Design may be hung.

Entrants may supply their own mat on the back of the acrylic cube.

Limited to 5 entries

Pedestal and Background colour: Tear Drop Blue 2053-60

Convenors:

Loris Adamson 905-655-7139 lorisadamson@me.com

Jacqui Miller 416-787-8727 millerjacqui@hotmail.com

Class 109 DYSFUNCTIONAL

A miniature design using dried and/or preserved plant material.

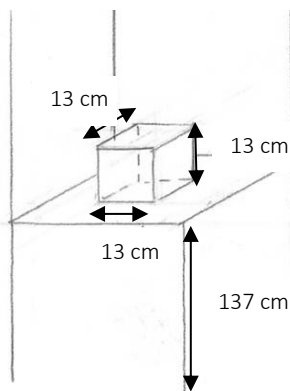

Staged in a clear acrylic cube 13 cm wide x 13 cm deep x 13 cm high (5.25" x 5.25" x 5.25") set on a pedestal 137 cm high (54") against a background. Design may be hung.

Entrants may supply their own mat on the back of the acrylic cube.

Limited to 5 entries

Pedestal and Background colour: Tear Drop Blue 2053-60

Convenors:

Linda Alcock 416-481-9894 linal22@yahoo.com

Marg Betts 416-699-3597 margbetts@rogers.com

Class 110 EXTENDED FAMILY

A Design

Staged on a shelf 122 cm wide x 61 cm deep (48" x 24") 91.5 cm (36") above the floor

Area Allotted: 112 cm wide x 76 cm deep x 116 cm high (44" x 30" x 46")

Limited to 5 entries

Background and Shelf colour: Blue Lake 2053-40; Frame: OC117 Simply White

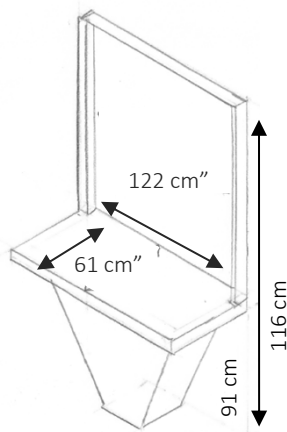

Convenors

Claudia Pedone 416-447-9122 claudia.j.pedone@gmail.com

Donalda Kelk 416-488-9493 dongeo@rogers.com

Class 111 THE BLACK SHEEP

A Design.



Staged on a black open sided pedestal 50 cm wide x 50 cm deep x 91 cm high (20" x 20" x 36") on a base 121 cm wide x 121 cm deep x 10 cm high (48" x 48" x 4") against a background panel 121 cm wide x 203 cm high (48" w x 80")

Area Allotted: 122 cm wide x 122 cm wide x 203 cm high (48" x 48" x 80").

Limited to 5 entries

Pedestal colour: Black. Base and background colour: Tear Drop Blue 2053-60

Convenors

Blythe Malloy 416-652-3733 blythemalloy@gmail.com

Class 112 FOREFATHERS

An Ikebana design

Staged on a pedestal 30 cm wide x 30 cm wide x 91 cm high (12" x 12" x 36") on a base 121 cm wide x 121 cm deep x 5 cm high (48" x 48" x 2" high) against a background panel 121 cm wide x 203 cm high (48" x 80")

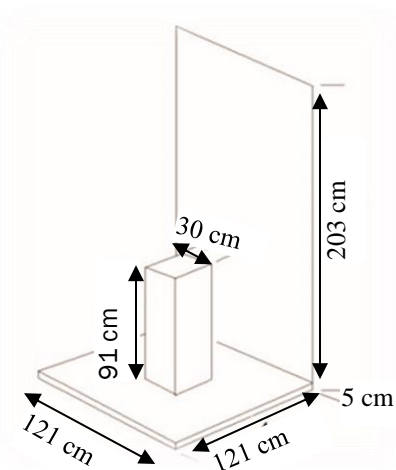

Area Allotted: 122 cm wide x 122 cm deep x 203 cm high (48" x 48" x 80").

Limited to 5 entries

Pedestal colour: Red 2000-10; Background and base colour: Blue Lake 2053-40

Convenors:

Sue Clarkson 416-763-3918 sueclarkson@gmail.com

Nora Cowie 416-486-0756 noracowie@rogers.com

Class 113 FAMILY FEUD

Open Class: Open to members of garden clubs and horticultural societies other than The Garden Club of Toronto

A design

Staged on a pedestal 30 cm wide x 30 cm deep x 91 cm high (12" x 12" x 36") on a base 121 cm wide x 121 cm deep x 5 cm high (48" x 48" x 2") against a background panel 121 cm wide x 203 cm high (48" x 80")

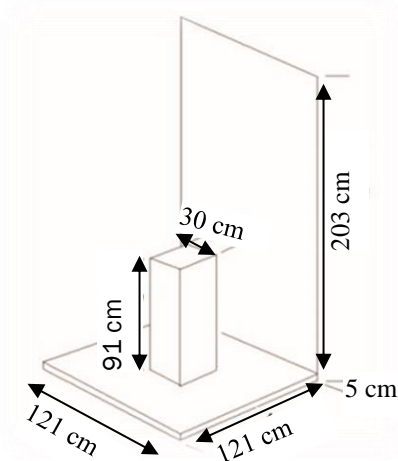

Area Allotted: 122 cm wide x 122 cm deep x 203 cm high (48" x 48" x 80").

Limited to 5 entries

Pedestal Colour: Tear Drop Blue 2053-60. Base and pedestal colour: Brilliant Blue 2065-30

Convenors

Marie Decker 905-844-1837 mardecker12@gmail.com

Mary McLean 416-443-3582 mmclean@dombre.com

Class 114 MOM'S BIRTHDAY

Open Class

Open to all members of garden clubs and horticultural societies **including** The Garden Club of Toronto.

A Buffet Table to be viewed from all sides but judged from the front.

Buffet tables are always functional. They are set for the actual service of food and judged from a standing position. Components should be conveniently and logically placed. Usually includes service for four or more. The decorative unit should be in proportion to the table, but is usually larger and more imposing than that for a seated table.

Exhibitors to provide their own table covers

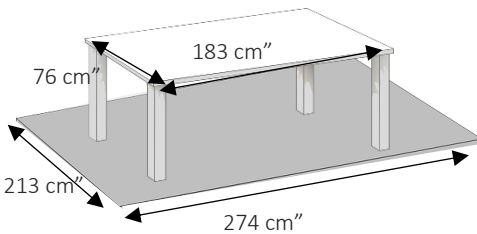

Staged on a table 183 cm wide x 76 cm deep x 74 cm high (72" x 30" x 29") sitting on a 213 cm deep x 274 cm wide (7' x 9') patio rug.

Rug/pattern/colour to be chosen at time of registration with convenor

Limited to 4 entries.

Convenors

Donna Buss 416-445-2843 gbuss@rogers.com

Carolyn Whiteside 416-231-1771 cwhiteside35@rogers.com

Class 115 WELCOME MAT

Open Class

Open to all members of garden clubs and horticultural societies **including** The Garden Club of Toronto

A design depicting a welcome mat, or a portion of a welcome mat. The mat should be made of dried, dyed, treated and/or plant-based material.

Other materials may be included but plant-based materials must predominate.

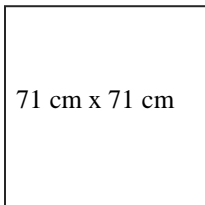

Staged: to be attached to a backdrop square board 71 cm wide x 71 cm high (28" x 28") already affixed to the wall. The exhibitor must equip the design unit with picture wire for hanging

Area Allotted: Material may extend over your own mat but must not exceed the dimensions of the 71 cm

wide x 71 cm deep (28" x 28") square; however, the exhibitor may choose the size and shape of their design.

Maximum depth: 7 cm (3") from the back to the front of the design.

First Day entry only. Limited to 18 entries. Exhibit will remain in the show for 10 days

Background Colour: Blue Lake 2053-400-10. Display Board Colour: Simply White OC-117

Convenors

Marilyn Walsh 416-461-8714 marilyn_walsh@rogers.com

Class 116 RELATIVELY SPEAKING

International Class

A Design

Staged on a base 121 cm wide x 121 cm deep x 10 cm high (48" x 48" x 4") against a background panel 121 cm wide x 203 cm high (48" x 80").

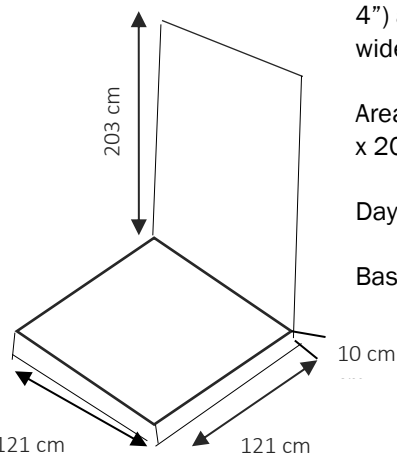

Area Allotted: 121 cm wide x 121 cm deep x 203 cm high (48" x 48" x 80")

Day 1 Entry, Limited to 10 entries

Base and Background: Blue Lake 2053-40

Convenors

Margaret Taylor 416-440-1344 margaret.taylor@mail.com

Sue Schaal 416-922-7875 schaal@sympatico.ca

DESIGN COMPETITION SCHEDULE DAY 2

Tuesday, March 12, 2019

Set up: Day 2 exhibits will be received between 6:30 p.m. and 11:00 p.m. on Tuesday, March 12 and between 6:00 a.m. and 9:00 a.m. on Wednesday, March 13, 2018.

Removal: Must be removed promptly on Sunday, March 17 at 5:00 p.m.

Class 201 FAMILY REUNION

NOVICE CLASS - Open to members of The Garden Club of Toronto who have not previously won a red ribbon in any major Garden Club of Toronto show or Toronto Flower Show (at Canada Blooms) (excluding monthly Neil Cup and Margaret Dove competitions).

A Mass design

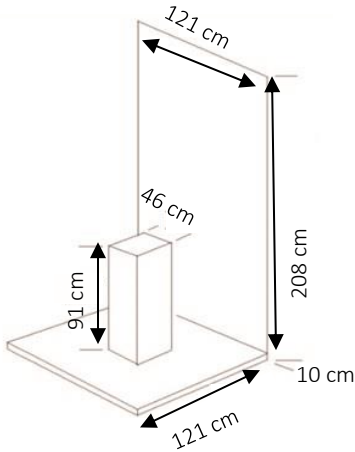

Staged on a pedestal 46 cm wide X 46 cm deep X 91 cm high (18" x 18" x 36") on a base 121 cm wide x 121 cm deep x 10 cm high (48" x 48" x 4") against a background panel 121 cm wide x 208 cm high (48" x 82").

Area Allotted: 121 cm wide x 121 cm deep x 203 cm high (48" x 48" x 82")

Limited to 5 entries

Pedestal, Base and background colour: Blue Lake 2053-40

Convenors:

Dianne Gillin 416-929-7176 dianne.sloangillin@gmail.com

Marsha Pine: 416-461-4466 mpine@rogers.com

Class 202 REMEMBER WHEN

A Reflective Design. A Design containing material(s) that reflect, give back image(s) of light or other components to the viewer. Reflective components are essential to the design and must appear throughout the design.

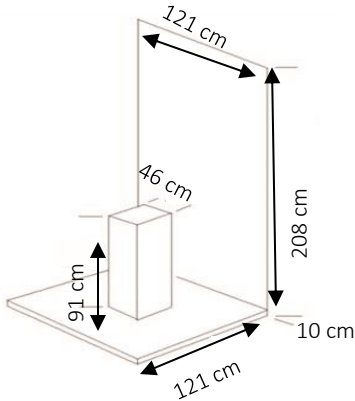

Staged on a pedestal 45 cm wide x 45 cm deep x 91 cm high (18" x 18" x 36") on a base 121 cm wide x 121 cm deep x 10 cm high (48" x 48" x 4") against a background panel 121 cm wide x 203 cm high (48" x 80")

Area Allotted: 121 cm wide x 121 cm deep x 203 cm high (48" x 48" x 80")

Limited to 5 entries

Pedestal, Base and background colour: 2053-40 Blue Lake

Convenors

Joyce Moffatt 416-445-0813 joycemoffat@rogers.com

Ellen Clark 416-486-9352 ellen.clark@sympatco.ca

CLASS 203 FAMILY SKELETONS

A Transparency Design. A design including a see-through material(s) that permits some components to be viewed through others. The see-through material(s) may be transparent, translucent, diaphanous, open grid or mesh, and may be plant based material or man-made materials. Depth is emphasized by positioning some solid materials in front of and some behind the see-through material(s).

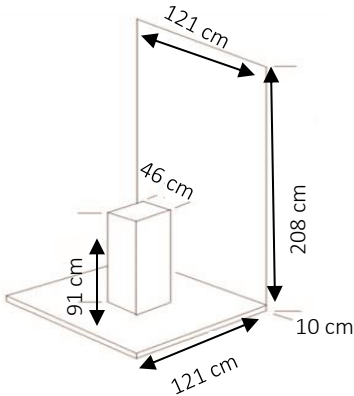

Limited to 5 entries

Staged on an acrylic pedestal 38 cm wide 38 cm deep x 91 cm high (15" x 15" x 36") on a 121 cm wide x 121 cm deep x 10 cm high base (48" X 48" X 4").

Area Allotted: 121 cm wide x 121 cm deep x 213 cm high (48" x 48" x 80").

Base and background: Blue Lake 2053-40

Convenors

Mary Lou Tigert 416-488-4991 mltigert@sympatico.ca

Katherine Shaw 416-480-9595 vkatherineshaw@gmail.com

Class 204 THE APPLE DOESN'T FALL FAR FROM THE TREE

A Hanging Design. A suspended design, not to exceed 10 lbs., to be judged at a comfortable viewing height.

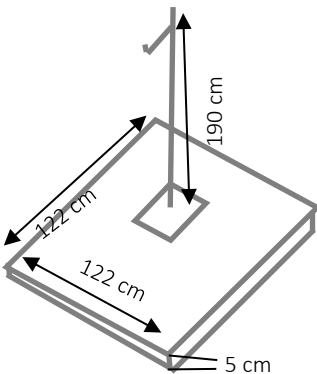

Staged to be hung from a black free-standing wrought iron stand on a base 122 cm wide x 122 cm deep x 5 cm high (48" x 48" x 2"). Hook for hanging will be approximately 190 cm (75") above the base.

Area Allotted: 122 cm wide x 122 deep cm (48" x 48")

Limited to 5 entries

Base and background: Brilliant Blue 2065-30

Convenors

Trudy Grantham 416-691-5333 tgrantham@sympatico.ca

Deborah Maw 416-966-2856 openarms@pathcom.com

Class 205 PATCHWORK QUILT

A Tapestry Design - A solid-mass design with a geometric closed silhouette(s). Imaginative design technique(s) and applications must be used, e.g. pillowing, pave, colour blocking, bunching, weaving, etc. Inner space is achieved by overlapping planes and/or other components, by groupings of like colours, textures, and forms, and/or by juxtaposing contrasting groupings or other components.

Staged on a shelf 122 cm wide x 61 cm deep (48" wide x 24") 91 cm (36") above the floor

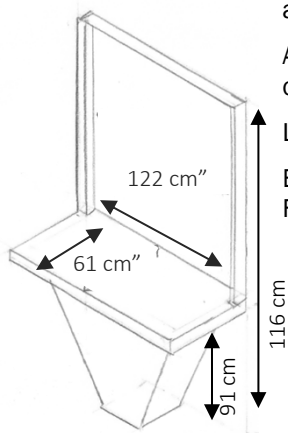

Area Allotted: 112 cm wide x 61 cm deep x 116 cm high (44" x 24" x 46")

Limited to 5 entries

Background and shelf: Brilliant Blue 2065-30.
Frame colour: Simply White OC117

Convenors

Deborah Landers 416-485-3557

landers@rogers.com

Celia Roberts 905-335-8555

celiaroberts62@bell.net

Class 206 MEMORIES

A Design in a 56 cm wide x 76 cm high (22" x 30") free standing frame. Frame will be supplied. Frame may be painted by exhibitor. Design may extend beyond frame.

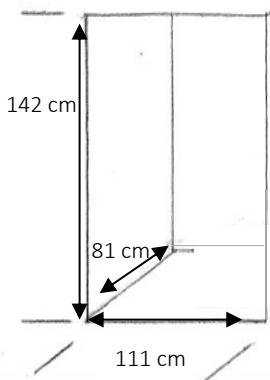

Staged in a niche 111 cm wide x 81 cm deep x 142 cm high (44" x 32" x 49")

Area Allotted: 111 cm wide x 81 cm deep x 142 cm high (44" x 32" x 49")

Limited to 5 entries

Niche colour: Red 2000-10

Set colour: Blue Lake 2053-40

Convenors

Heather Gray 416-445-2910 hgrayis@rogers.com

Ellen Clark 416-486-9352 ellen.clark@sympatico.ca

Class 207 ALL SNUGGLED UP

A Pave Design. Pavé is a technique of placing groups of plant material that have been cut short, close together to form undulating mounds of colours, textures, shapes and sizes. Any plant material, e.g., flowers, foliage, cut stems, fruits, vegetables, moss, etc. can be used.

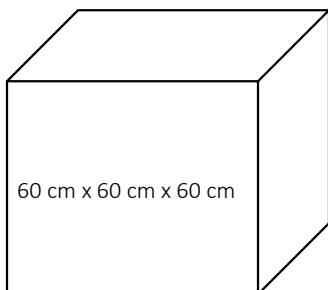

Staged on a cube 60 cm wide x 60 cm deep x 60 cm high (24" x 24" x 24")

Area Allotted: 76 cm wide x 76 cm deep (30" x 30")

Limited to 5 entries

Cube colour: Brilliant Blue 2065-30

Convenors

Tara Bramall 416-489-5383 tara8@rogers.com

Janet Marsh 416-483-7417 janetem12@icloud.com

Class 208 SOUL MATES

A miniature design using predominately fresh plant material.

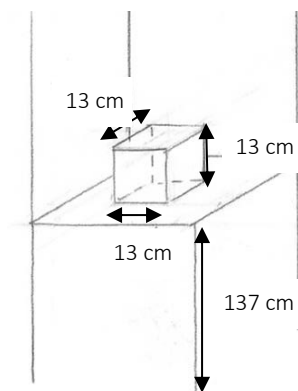

Staged in a clear acrylic cube 13 cm wide x 13 cm deep x 13 cm high (5.25" x 5.25" x 5.25") set on a pedestal 137 cm high (54") against a background. Design may be hung. Entrants may supply their own mat on the back of the acrylic cube.

Limited to 5 entries

Pedestal and Background colour: Tear Drop Blue 2053-60

Convenors:

Loris Adamson 905-655-7139 lorisadamson@me.com

Jacqui Miller 416-787-8727 millerjacqui@hotmail.com

CLASS 209 NUCLEAR FAMILY

A miniature design using dried and/or preserved plant material.

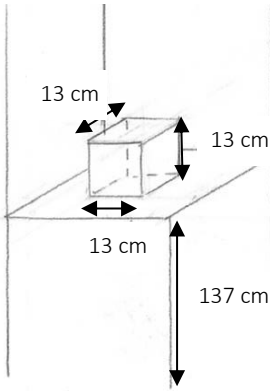

Staged in a clear acrylic cube 13 cm wide x 13 cm deep x 13 cm high (5.25" x 5.25" x 5.25") set on a pedestal 137 cm (54" high) against a background. Design may be hung. Entrants may supply their own mat on the back of the acrylic cube.

Limited to 5 entries

Pedestal and Background colour: Tear Drop Blue 2053-60

Convenors

Linda Alcock 416-481-9894 linal22@yahoo.com

Marg Betts 416-699-3597 margbetts@rogers.com

Class 210 DISTANT COUSINS

A Design

Staged on a shelf 122 cm wide x 61 cm deep (48" x 24") 91.5 cm (36") above the floor

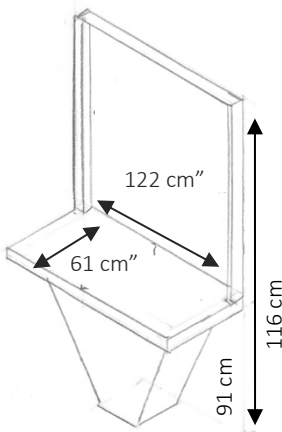

Area Allotted: 112 cm wide x 76 cm deep x 116 cm high (44" x 30" x 46")

Limited to 5 entries

Background and Shelf colour: Blue Lake 2053-40: Frame colour: OC117 Simply White

Convenors

Claudia Pedone 416-447-9122

claudia.j.pedone@gmail.com

Donalda Kelk 416-488-9493

dongeo@rogers.com

Class 211 SIBLING RIVALRY

A Design.

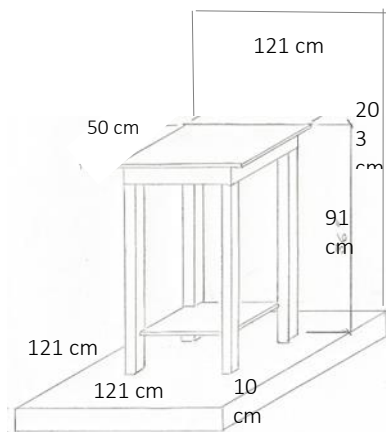

Staged on a black open sided pedestal 50 cm wide x 50 cm deep x 91 cm high (20" x 20" x 36") on a base 121 cm wide x 121 cm deep x 10 cm high (48" x 48" x 4") against a background panel 121 cm wide x 203 cm high (48" w x 80" high)

Area Allotted: 91 cm wide x 91 cm deep x 203 cm high (48" x 48" x 80").

Limited to 5 entries

Pedestal colour: Black. Base and background colour: Tear Drop Blue 2053-60

Convenors

Blythe Malloy 416-652-3733 blythemalloy@gmail.com

Class 212 TRADITIONS

An Ikebana design

Staged on a pedestal 30 cm wide x 30 cm deep x 91 cm high (12" x 12" x 36") on a base 121 cm wide x 121 cm deep x 5 cm high (48" x 48" x 2") against a background panel 121 cm wide x 203 cm high (48" x 80")

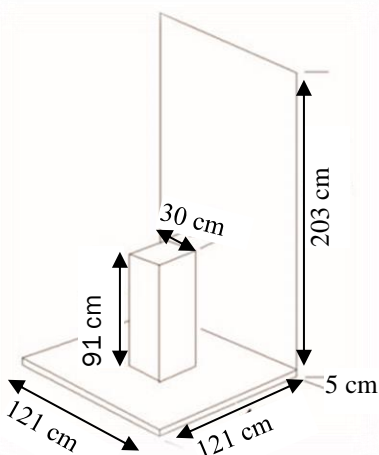

Area Allotted: 122 cm wide x 122 cm deep x 203 cm high (48" x 48" x 80").

Limited to 5 entries

Pedestal colour: Red 2000-10;
Background and base colour: Blue Lake 2053-40

Convenors:

Sue Clarkson 416-763-3918
sueclarkson@gmail.com
Nora Cowie 416-486-0756
noracowie@rogers.com

Class 213 FAMILY DYNAMICS

Open Class: Open to members of garden clubs and horticultural societies other than The Garden Club of Toronto

A design

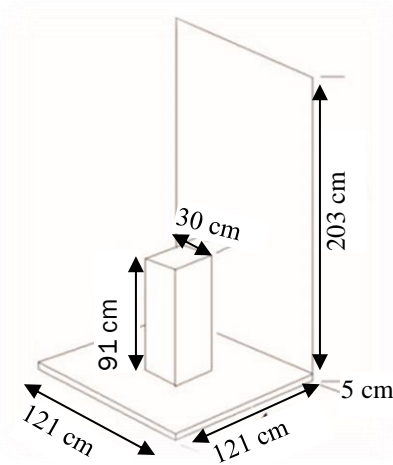

Staged on a pedestal 30 cm wide x 30 cm deep x 91 cm high (12" x 12" x 36") on a base 121 cm wide x 121 cm deep x 5 cm high (48" x 48" x 2") against a background panel 121 cm wide x 203 cm high (48" x 80")

Area Allotted: 121 cm wide x 121 cm deep x 213 cm (48" x 48" x 84")

Limited to 5 entries

Pedestal Colour: Tear Drop Blue 2053-60. Base and pedestal colour: Brilliant Blue 2065-30

Convenors

Marie Decker 905-844-1837 mardecker12@gmail.com

Mary McLean 416-443-3582 mmclean@dombre.com

Class 214 DAD'S BIRTHDAY

Open Class; Open to all members of garden clubs and horticultural societies **including** The Garden Club of Toronto.

A Buffet Table to be viewed from all sides but judged from the front.

Buffet tables are always functional. They are set for the actual service of food and judged from a standing position. Components should be conveniently and logically placed. Usually includes service for four or more. The decorative unit should be in proportion to the table, but is usually larger and more imposing than that for a seated table.

Exhibitors to provide their own table covers

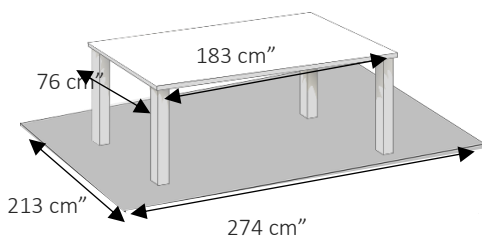

Staged on a table 183 cm wide x 76 cm deep x 74 cm high (72" x 30" x 29") sitting on a 213 cm deep x 274 cm wide (7' x 9') patio rug.

Rug/pattern/colour to be chosen at time of registration with convenor

Limited to 4 entries

Convenors:

Donna Buss 416-445-2843 gbuss@rogers.com

Carolyn Whiteside 416-231-1771 cwhiteside35@rogers.com