

## Design Competition Rules

### Judging Criteria

**NOTE: Anyone judging Horticultural or Design classes at this show may NOT enter any Horticultural or Design class on either day.**

1. All Design and Horticultural exhibits will be judged by a designated team of judges selected by the Toronto Flower Show Convenors.
2. Judges at this year's show will not be permitted on the show floor during entry times for exhibits.
3. No one other than those authorized by the Show Committee will be permitted into the area of the Toronto Flower Show where judging is in progress and no one may discuss the exhibits with the judges prior to judging.
4. Designs must not be altered in any manner after judging. Deteriorating plant material however, must be replaced in order to keep the exhibit in show condition.
5. The decision of the Judges is final.

**The following rules apply to all Design Competitions. Note that only non-professionals may compete.**

1. General Regulations (pages 7, 8) Judging Criteria (above) and the *Ontario Judging and Exhibiting Standards for Horticulture and Floral Design* (2003 edition) apply. In addition, International Flower Show Rules, World Association of Floral Artists (WAFA) will apply:
  - a) An exhibit is made of plant material, with or without accessories, within a space specified in the Show Schedule.
  - b) Plant material must predominate over all other components of the exhibit.
  - c) The use of artificial plant material is forbidden unless stated in the regulations.
  - d) Fresh plant material must be in water or in water-retaining material unless such material remains turgid throughout the event.
  - e) Painted and/or artificially coloured plant material may be used unless otherwise stated in the regulations.
  - f) Pre-prepared work must not predominate in the exhibit.

In the event of any conflict, WAFA rules will prevail.

2. Exhibitors are requested to notify Convenors as soon as possible, which dates and classes they wish to enter. Do not wait to be called. Space will be reserved for each exhibit when notice is received and confirmed by email, telephone or letter. **Exhibitors unable to fulfill their responsibility must find their own substitute.**
3. Exhibitors may enter a maximum of 4 classes per entry day, but may submit only one exhibit in each class.

4. All classes are limited to 5 exhibits each entry day except where noted in the Schedule.
5. First day exhibits will be received between 8:00 p.m. and 11:00 p.m. on Wednesday March 9, and between 7:00 a.m. and 12:30 p.m. on Thursday, March 10, 2016. First day exhibits must be removed at 7:00 p.m. on Tuesday, March 15, 2016.
6. Second day exhibits will be received between 8:00 p.m., Tuesday, March 15 and 1:00 a.m., Wednesday March 16, or between 7:00 a.m. and 9:00 a.m. on Wednesday, March 16, 2016.
7. All designs must be in place and ready for the Passing Committee at the following times:

**Thursday, March 10, by 12:30 p.m.** for judging at 1:00 p.m.

**They must remain in place until removal on Tuesday, March 15 at 7:00 p.m.**

**Wednesday, March 16 by 9:00 a.m.** for judging at 9:30 a.m.

**There will be a warning bell 15 minutes prior to the time of clearing the judging area on both entry days.**

8. All Exhibits must be kept in show condition. Deteriorating plant material must be replaced.
9. If a design has a mechanical failure after the entry time is closed, it may not be repaired until judging is completed. After judging it must be repaired to its original status for the duration of the show.
10. No exhibit may be altered in any manner after it has been judged, except to restore it to its original condition according to rule #8 or #9.
11. Maintenance may be done at any time during the show, including public open hours. Please ensure that you are wearing appropriate ID.
12. The Toronto Flower Show Chair and/or the Floral Design Chair may remove an exhibit if deemed necessary.
13. All exhibits must be removed promptly on Sunday, March 20 at **5:00 p.m.**
14. **All designs must be made and staged by the exhibitors themselves. Any competitor receiving help with put-in other than help that is physically necessary will be disqualified.**
15. All exhibitors are asked to leave their completed entry sheet with their design at the time of entry. It should include: name, class, date, a list of plant material in the design, including both common and botanical names and explanation of containers of interest. See *Snippy Tips #1*. **Novice designation must be included on the entry sheet.** The list of material in the design should be duplicated, in block capitals or typed to be available for the judges.
16. Check with your class convenor to see that your design meets all requirements set out in the schedule. **A design which does not comply will not be judged.**

This will be at the sole discretion of the Design Committee Chair. **You may not leave the design area until your design is accepted by the Passing Committee.** This will be indicated by the letter **P** marked on your entry card.

17. While every effort has been made to ensure accuracy, note that measurements may vary slightly.

Regarding liability - see General Regulations page 7.

**Points Awarded**

|                    |          |
|--------------------|----------|
| First              | 6 points |
| Second             | 4 points |
| Third              | 2 points |
| Honourable Mention | 1 point  |

**Scale of Judging Points** (except where otherwise stated)

|   |           |
|---|-----------|
| Design: Organization of the elements and principles.<br>points  | 35        |
| Conformance: Compliance with scheduled requirements, theme.   | 25 points |
| Creativity: Originality of concept in choice of components, and/or organization of design elements according to the principles of design. | 20 points |
| Distinction and Condition: Marked superiority and physical state of plant material at time of judging.                                    | 20 points |

Scale of Points for Tables: see *Ontario Judging Standards* (2003 edition)

Scale of Points for Miniatures: see *Ontario Judging Standards* (2003 edition)

**Deductions will be proportionate to the degree of non-compliance.**

Note: throughout the schedule, \* denotes Benjamin Moore Paint Colour

**DESIGN COMPETITIONS "IT'S A PARTY"**

**The Garden Club of Toronto Classes**

**Open to members of The Garden Club of Toronto**

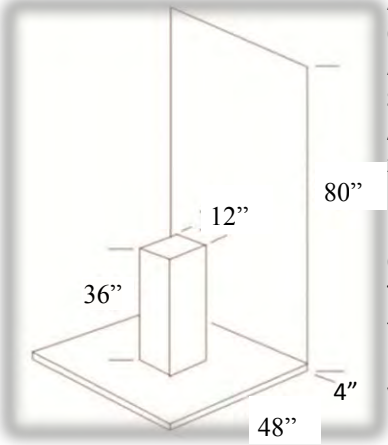

**CLASS 101 NATURE'S PARTY**  
A Vegetative Design 1<sup>st</sup> Entry Day

**CLASS 201 ON THE ROCKS**  
A Vegetative Design 2<sup>nd</sup> Entry Day

**Staged:** on a pedestal.

**Area Allotted:** 122cm wide x 122cm deep x 213cm high (48" x 48" x 80")

**Pedestal, Base and Background Colour:**  
Iced Slate 2130-60\*

**Convenors:**

Trudy Grantham 416-691-5333

tgrantham@sympatico.ca

*and*

Katherine Shaw 416-480-9595

vkatherineshaw@gmail.com

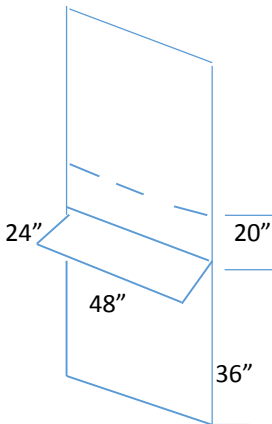

**CLASS 102 FETE**  
A Design using multiple containers  
1<sup>st</sup> Entry Day

**CLASS 202 FIESTA**  
A Design 2nd Entry Day

**Staged:** on a floating shelf

**Area Allotted:** 122cm wide x 61cm deep x 51cm high (48" x 24" x 20")

**Background and Shelf colour**  
Caribbean Coast 2065-60\* (Area above 20" background is Iced Slate 2130-60\*)

**Convenors:**

Joyce Moffat 416-445-0813

Diane Gillin 416-929-7176

joycemoffat@rogers.com (class 102)

diane.sloangillin@gmail.com (class 202)

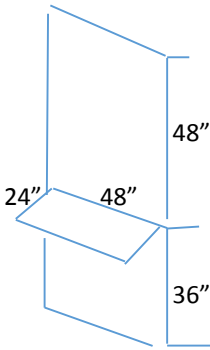

**CLASS 103**      **PAINT THE TOWN RED**  
A Design      1st Entry Day

**CLASS 203**      **EXCITEMENT**  
A Design incorporating metal  
2<sup>nd</sup> Entry Day

**Staged:** on a floating shelf

**Area Allotted:** 122cm wide x 61 cm deep  
x 122cm high (48" x 24" x 48")

**Background and Shelf Colour:**  
Caribbean Coast 2065-60\*

**Convenors:**

Margaret Betts 416-699-3597

margbetts@rogers.com (class 103)

Lynda Summerville 416-690-5434

dean.lynda@rogers.com (class 203)

**CLASS 104**      **WINGDING**  
A Miniature Design using predominantly  
fresh plant material.      1<sup>st</sup> Entry Day

**CLASS 204**      **HIGH JINKS**  
A Miniature Design using predominantly  
fresh plant material.      2<sup>nd</sup> Entry Day

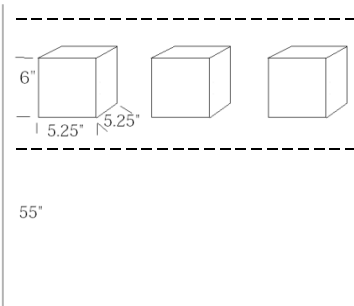

Design must not exceed 12.5cm (5") in  
any direction.

**Staged:** in an acrylic box. Design may be  
hung. Exhibitor may provide a matte for  
the background and floor of the box.

**Set Colour:** Iced slate 2130-60\*  
with Seattle Grey 2130-70\* band.

**Convenors:**

Margaret Betts 416-699-3597

margbetts@rogers.com *and*

Jackie David 416-4875231

jackiedavid@hotmail.com

\*Benjamin Moore paint colour

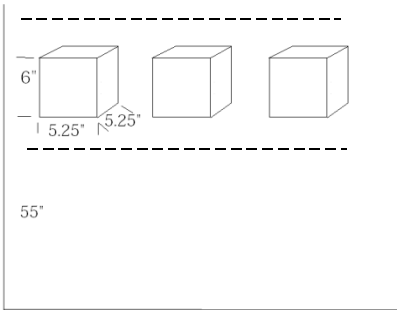

**CLASS 105 WHIRL**  
 A Miniature Design using dried plant material.  
 1<sup>st</sup> Entry Day

**CLASS 205 WHOOP-DE-DO**  
 A Miniature Design using dried plant material.  
 2<sup>nd</sup> Entry Day

Design must not exceed 12.5cm (5")  
 In any direction.

**Staged:** in an acrylic box. Design may be hung. Exhibitor may provide a mat for the background and floor of the box.

**Set Colour:** Iced slate 2130-60\* with Seattle Grey 2130-70\* band.

**Convenors:**

Loris Adamson 905-655-7139  
 Linda Alcock 416-481-9894

lorisadamson@me.com and  
 linal22@yahoo.com

**CLASS 106 PICNIC IN THE PARK**

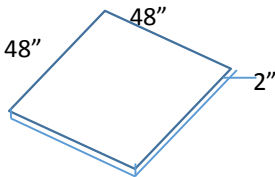

A functional table set as a picnic on the ground.  
 1<sup>st</sup> Entry Day

**Staged:** on exhibitor's own cloth on the ground, on a base.

**Note:** plant material need not predominate.

**Area allotted:** 122cm x 122cm (48" x 48")  
 Height unlimited.

**4 entries.**

**Convenor:**

Jacqui Miller 416-787-8727

millerjacqui@hotmail.com

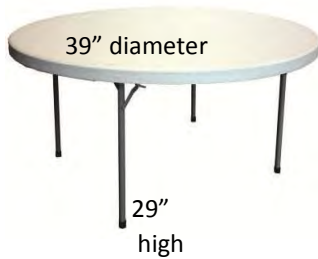

**CLASS 206 DINNER IN THE GARDEN**

A Functional Table 2<sup>nd</sup> Entry Day

**Note:** plant material need not predominate

**Area allotted:** 122cm x 122 cm (48" x 48") Height unlimited.

**4 entries.**

**Convenor:**

Judy James 416-960-2010 judithejames@rogers.com

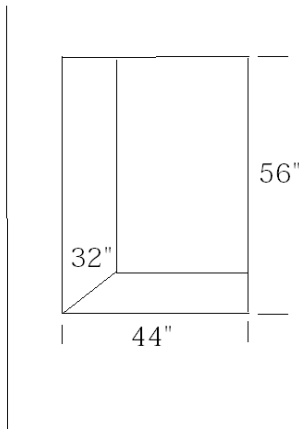

**CLASS 107 DIVERSION**

An Abstract Design 1<sup>st</sup> entry day

**CLASS 207 CONGA LINE**

An Abstract Design 2<sup>nd</sup> entry day

**Staged:** in a niche. Design may be hung.

**Area Allotted:** 115 cm wide X 81 cm deep X 142 cm high (44" x 32" x 56")

**Set Colour:** Iced Slate 2130-60\*

**Inside Niche Colour:**

Caribbean Coast 2065-60\*

**Convenors:**

Donalda Kelk 416-488-9493 dongeo@rogers.com *and*  
 Diana Kennedy 905-831-9671 diana.kennedy@sympatico.ca

\* Benjamin Moore paint colour

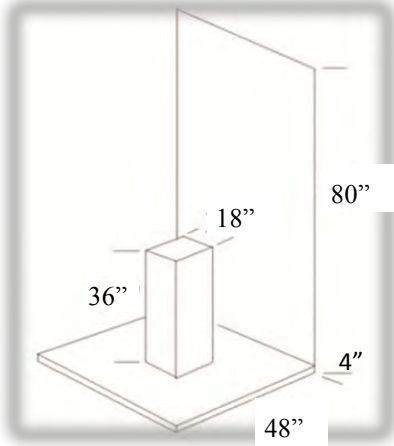
**CLASS 208****BOLD IS BEAUTIFUL**

A Mass Design  
2<sup>nd</sup> Entry Day

**Staged:** on a pedestal.

**Area Allotted:** 122cm wide x 122cm deep  
x 213cm high (48" x 48" x 80")

**Base, Background and Pedestal Colour:**  
Caribbean Coast 2065-60\*

**Convenor:**

Joyce Moffat 416-445-0813  
joycemoffat@rogers.com

**CLASS 209****INSPIRED BY....**

A Design inspired by a photo  
2<sup>nd</sup> Entry day

**Staged:** on a pedestal. Photo (8" x 10")  
to be mounted beside the pedestal in an  
8" x 10" picture frame, provided.

**Area Allotted:** 122cm wide x 122cm deep  
X 213cm high (48" x 48" x 80")

**Base, Background and Pedestal Colour:**  
Caribbean Coast 2065-60\*

**Convenor:**

Ellen Clark 416-486-9352  
ellen.clark@sympatico.ca

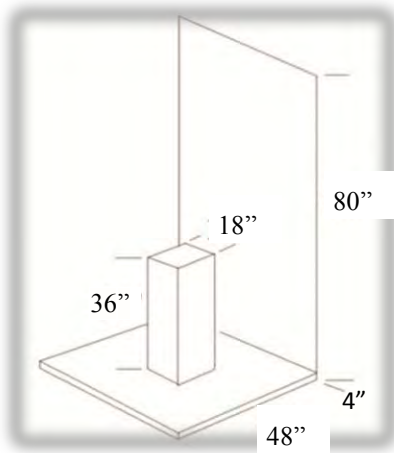



**CLASS 110      GLADRAGS**

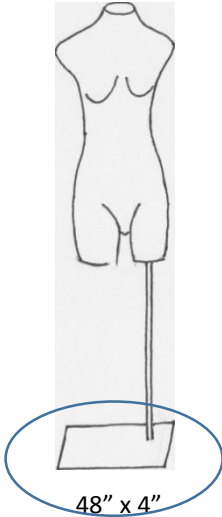

A Mannequin dressed with fabric and plant materials. 1<sup>st</sup> Entry Day.  
This exhibit will remain in the show for 10 days.

**Staged:** on a circular base. To be viewed all around but judged from the front.  
Mannequin provided.

**Area allotted:** circular area with a 122cm (48") diameter. No height restriction.

**Disc colour:** Iced Slate 2130-60\*

**5 entries**

**Convenor:** Rosemary Passafiume McLean 416-284-6959  
rosemary.passafiume.mclean@gmail.com

**CLASS 111      MASQUERADE**

A mask made from dried plant material. Material may be painted and/or treated.

1st Entry Day

To remain in place for 10 days.

**staged:** on a pedestal with a 46cm (18") diameter top. Mounted on a 38cm x 38cm (15" x 15") black board set on an easel atop the pedestal. Board and easel will be supplied ahead of time.

**Area Allocated:** 46cm x 46cm (18" x 18")

**Pedestal and Top Colour:**  
Caribbean Coast 2065-60\*

**5 entries**

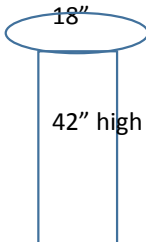

**Convenor:** Marsha Pine 416-461-4466 mpine@rogers.com

\* Benjamin Moore paint colour

**NOVICE CLASS**

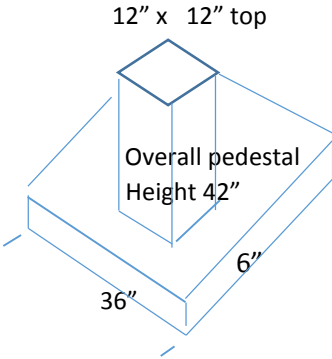

**Convenors:**

Deborah Landers 416-485-3557 landers@rogers.com *and*  
Donna Buss 416-445-2843 gbuss@rogers.com

**CLASS 112**

A Design

**PARTY TIME**

1<sup>st</sup> Entry Day

**CLASS 212**

A Hand-tied Bouquet

**FOR THE HOSTESS**

2<sup>nd</sup> Entry Day

Exhibited in Designer's own container.

**Staged:** on a pedestal. Viewed from the front but judged all around

**Area Allotted:** 40cm wide x 40cm deep (16" x 16") No height restriction

**Pedestal and Base Colour:**

Iced Slate 2130-60\*

## **OPEN CLASSES**

**Open to all members of garden clubs and horticultural societies *including* The Garden Club of Toronto**

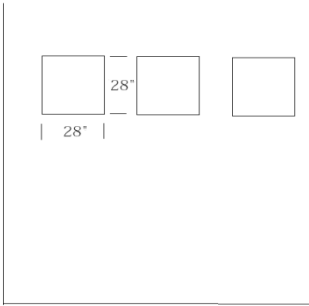

### **CLASS 113 ENTERTAIN**

An assemblage 1<sup>st</sup> Entry Day.

This exhibit will remain in the show for 10 days. A three dimensional abstract design combining previously unrelated plant material and found objects into an integrated whole.

**Staged:** to be attached to a backdrop board 71cm X 71cm (28" x 28") square already affixed to the wall. The exhibitor must equip the assemblage with a picture wire for hanging on the board.

**Area allotted:** material may not exceed the dimensions of 71cm x 71 cm (28" x 28") square, however the exhibitor may choose the size and shape of their design.

**18 Entries accepted.**

**Background colour:** Iced Slate 2130-60\*

**Display Board colour:**

Seattle Grey 2130-70\*

### **Convenor:**

Marilyn Walsh 416-461-8714 [marilyn\\_walsh@rogers.com](mailto:marilyn_walsh@rogers.com)

\* Benjamin Moore paint colour

Open to all members of garden clubs and horticultural societies other than  
The Garden Club of Toronto

overall  
pedestal  
height  
42"

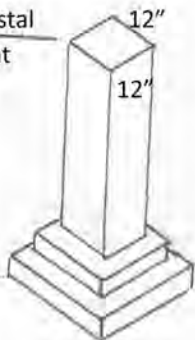

**CLASS 114**

A Design

**HOSTESS GIFT**

1st Entry Day

**CLASS 214**

A Design

**LOOT BAG**

2<sup>nd</sup> Entry Day

**Staged:** on a pedestal. Judged from the front but viewed all around.

**Area Allotted:** 30cm wide x 30cm deep (12" x 12") Height unlimited.

**Pedestal Colour:**

Iced Slate 2130-60\*

**Convenors:**

Ursula Eley

416-699-4353

eley@rogers.com

and

Judy Zinni

905-820-3807

jzinni@bell.net

**INTERNATIONAL CLASS**

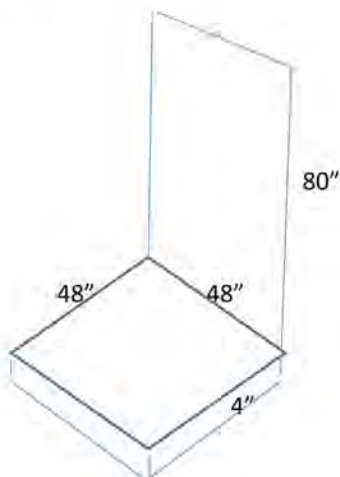

**CLASS 115**

A Design

**CELEBRATE!**

1<sup>st</sup> Entry Day

**Staged:** on a base

**Area Allotted:** 122cm x 122cm x 203cm (48" x 48" x 80")

**Base and Background colour:**

Caribbean Coast 2065-60\*

**Entries:** Invitational class. **10 exhibitors**

**Note:** Exhibits to remain in place until 7 PM Tuesday March 15, 2016

**Convenor:** Sue Schaal

416-922-7875

schaal@sympatico.ca

## Ikebana Class

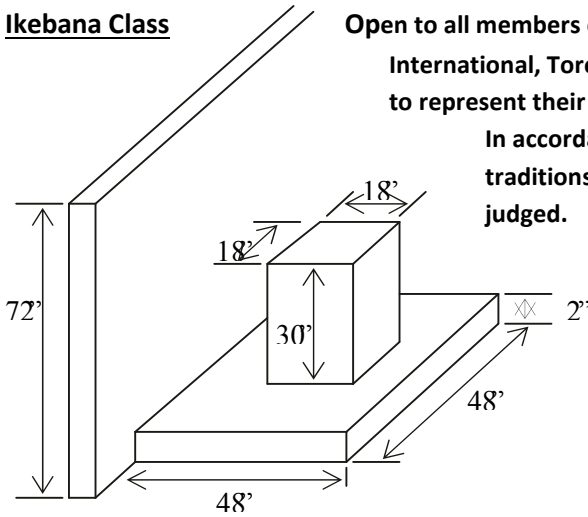

**Open to all members of Ikebana**

**International, Toronto Chapter, chosen to represent their schools.**

**In accordance with Ikebana traditions, this class is not judged.**

### **CLASS 116 SERENITY**

An Ikebana Design 1<sup>st</sup> Entry Day

### **CLASS 216 TRANQUILITY**

An Ikebana Design 2<sup>nd</sup> Entry Day

**Staged:** on a pedestal

**Area Allotted:** 122cm x 122cm x 183cm (48" x 48" x 72")

**Background, Base and Pedestal colour:**

Iced Slate 2130-60\*

**Convenor:**

Sue Clarkson 416-783-3918 sueclarkson@gmail.com

Nora Cowie 416-486-0756 noracowie@rogers.com

\* Benjamin Moore paint colour

# Flower Show Awards

Awards will be presented on the show floor on Sunday, March 20, 2016 at 3:30 p.m.

## General Awards

Open to all exhibits excluding the International Class

1. **Kathy Dembroski Awards**, for Judges' Choice for:  
(a) an entry with the most fascinating and intriguing design in **Design** and  
(b) an entry with the most fascinating and intriguing design in **Horticulture**,  
Sections A to G inclusive.

## The Garden Club of Toronto Awards

Open to members of The Garden Club of Toronto

2. **The Libra Award**, to the exhibitor who wins a first in Design as well as Horticulture. In Horticulture, no classes with newly acquired plant material are to be considered. Herb classes and Educational classes are eligible as long as they do not include newly acquired material. Only 1 competitor may win this award.

## Horticultural

### Points Awarded

|                                    |          |
|------------------------------------|----------|
| Green Ribbon (Award winning entry) | 2 points |
| First                              | 6 points |
| Second                             | 4 points |
| Third                              | 2 points |
| Honourable Mention                 | 1 point  |

3. **Green Thumb Award**, Judges' choice for the exhibit demonstrating outstanding horticultural skills. All Horticultural classes in Sections A, B, C, D and E are eligible.
4. **Anniversary Award**, for the highest aggregate number of points in Sections A, B, C D and E in the Horticulture classes.
5. **Helen Cochrane Novice Award**, for the best exhibit in Class 20 by a member of The Garden Club of Toronto who has not previously won a first place ribbon in a Horticultural class at our annual show.
6. **Jane McArthur Award**, for the best exhibit in a class that is both educational and challenging, in Classes 16 -19 inclusive and 21 – 24 inclusive.

7. **Lee Valley Award**, for the best exhibit in Classes 1-15 inclusive and 21 -24 inclusive.
8. **William Neilson Award**, Judges' Choice for the best exhibit combining design and horticultural excellence in Classes 28 and 29.
9. **The Garden Club of Toronto Horticultural Bowl**, for Judges' Choice in Class 30 and 31.
10. **Jane Donnelly Award**, for the best interpretive design in Horticulture in Class 32.

## Herb

11. **Elizabeth Bryce Award**, for the best exhibit in Herb Classes 26 – 29 inclusive.
12. **Evelyn Meagher Award**, for the highest number of points in Herb Classes 26 – 29.

**Note:** The designation "Judges' Choice" gives judges the freedom to choose a particular exhibit. It is not necessarily one which won a first

## Design

### Points Awarded

|                                    |          |
|------------------------------------|----------|
| Green Ribbon (Award winning entry) | 2 points |
| First                              | 6 points |
| Second                             | 4 points |
| Third                              | 2 points |
| Honourable Mention                 | 1 point  |

*All Design classes are eligible for 1st, 2nd, 3rd and Honourable Mention ribbons with the following exceptions: 115 which will be point scored and Gold, Bronze, Silver or Highly Commended rosettes will be awarded according to the points achieved.*  
Classes **116 and 216 are not** to be judged.

16

14. **Founders' Gold Cup**, for creative works of *outstanding beauty* in a design which includes fresh plant material. Members may win the Gold Cup any number of times. Miniature designs, Table designs and Class 110 GLADRAGS, Class 111, MASQUERADE, and Class 113, ENTERTAIN are not eligible for the Gold Cup.

15. **The Katherine Hobbs Award**, for *distinctive design*. Open only to winners of the Founders Gold Cup and to members who have been contenders for the award since its inception (not including this show). Members may win the Hobbs Award any number of times. All competitive exhibits by Hobbs winners and contenders will be eligible each entry day, except for Miniature Designs, Table Designs and Class 110, GLADRAGS, Class 111, MASQUERADE, and Class 113, ENTERTAIN.
  
16. **The Garden Clubs of Ontario Award**, Judges' Choice for the *most creative design* by the Garden Club member who has never been a contender for the Katherine Hobbs Award. Katherine Hobbs Award contenders for this show are not eligible.
  
17. **Helen Cochrane Novice Award**, Judges' Choice for the *most distinctive design* by a member of The Garden Club of Toronto who has not previously won a first place ribbon in a design class at a Garden Club of Toronto Annual Show. Novices must declare eligibility for this award to the Convenor at entry time.
  
18. **Joyce Girvan Award**, Judges' Choice for *best mass design* in any class except the Table class.
  
19. **The Garden Club of Toronto Silver Anniversary Rose Bowl**, Judges' Choice for the *most distinctive Table Design* in Class 106 and 206.
  
20. **The Garden Club of Toronto Silver Trillium Award**, Judges' Choice for the *most distinctive Miniature Design* in Classes 104, 204, 105 and 205.
  
21. **TD Bank Group Award**, Judges' Choice for the *most distinctive design* in Class 110, GLADRAGS, and 111, MASQUERADE
  
22. **Camston Award**, awarded to the competitor with the highest aggregate number of points in the Design Section obtained during the show.
  
23. **Award for Colour**, awarded for the best use of colour in the Design Section.

## International Design Award

24. **The Heather Fuller Award**, Judges' Choice in the International Class 115.



## Open Class Awards

### Horticultural

25. **Tommy Thompson Award**, for the best exhibit in Sections A and B, excluding those of any member of The Garden Club of Toronto.
26. **Canada Blooms Award**, best exhibit in Classes 1 - 4 inclusive.
27. **Canada Blooms Award**, best exhibit in Classes 5 - 7 inclusive.
28. **Canada Blooms Award**, best exhibit in Classes 8 and 9.
29. **Canada Blooms Award**, best exhibit in Classes 10 - 13 inclusive.
30. **Canada Blooms Award**, best exhibit in Classes 14 and 15.
31. **Canada Blooms Award**, best exhibit in Classes 16 and 17.
32. **Canada Blooms Award**, best exhibit in Classes 18 and 19.
33. **Garden Clubs of Ontario Award**, best exhibit in Class 33.
34. **Toronto Botanical Gardens Award**, Judges' Choice in Class 34.
35. **Canada Blooms Award of Horticultural Excellence** for the highest aggregate number of points for an Open Class exhibitor in Sections A, B, C and G, excluding members of The Garden Club of Toronto.

### Design

36. **The Garden Club of Toronto Award**, for the most distinctive design in Classes 114, HOSTESS GIFT and 214, LOOT BAG.
37. **Canada Blooms Award**, for Judges' Choice in Class 113, ENTERTAIN . All entries in this class, including those by Garden Club of Toronto members, are eligible for this award.
38. **Upper Canada House Award**. Open to Garden Club of Toronto members only. For the best interpretation of the theme of the show. All Horticultural and Design classes are eligible.

### Professional Florist Award

Honourary Award in Recognition of a Professional Florist at Canada Blooms chosen for their contribution to the Toronto Flower Show.